

PORTER

"STANDARD" HEPWORTH TOWEL RAIL SMALL WALL

Porter heated towel rails are constructed from the highest grade corrosion resistant DZR brass. The quality of finish is reminiscent of yacht rail styling, durable and beautiful. The dual fuel floor mounted models can be configured with a hidden electrical heating element. Each unit is rigorously tested to ensure the correct heat output and further pressure tested to fourteen bar.

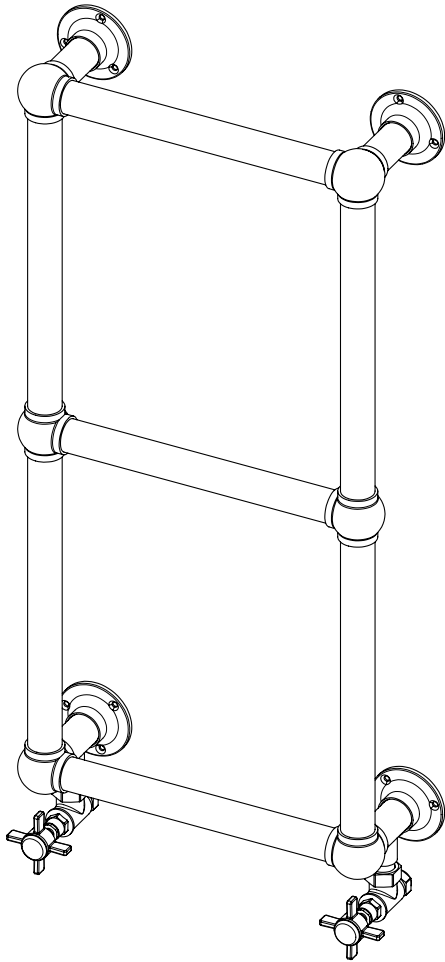

TR728

	MM	"
Width	400	15.7
Height	800	31.5
Depth	125	4.9

DETAILS

Made from high grade corrosion resistant DZR brass. 450 BTU

FINISHES

Polished chrome



Silver nickel



Polished brass



Antique brass



PORTER

"STANDARD" HEPWORTH TOWEL RAIL SMALL WALL

TR728

PLAN AND DIMENSIONS

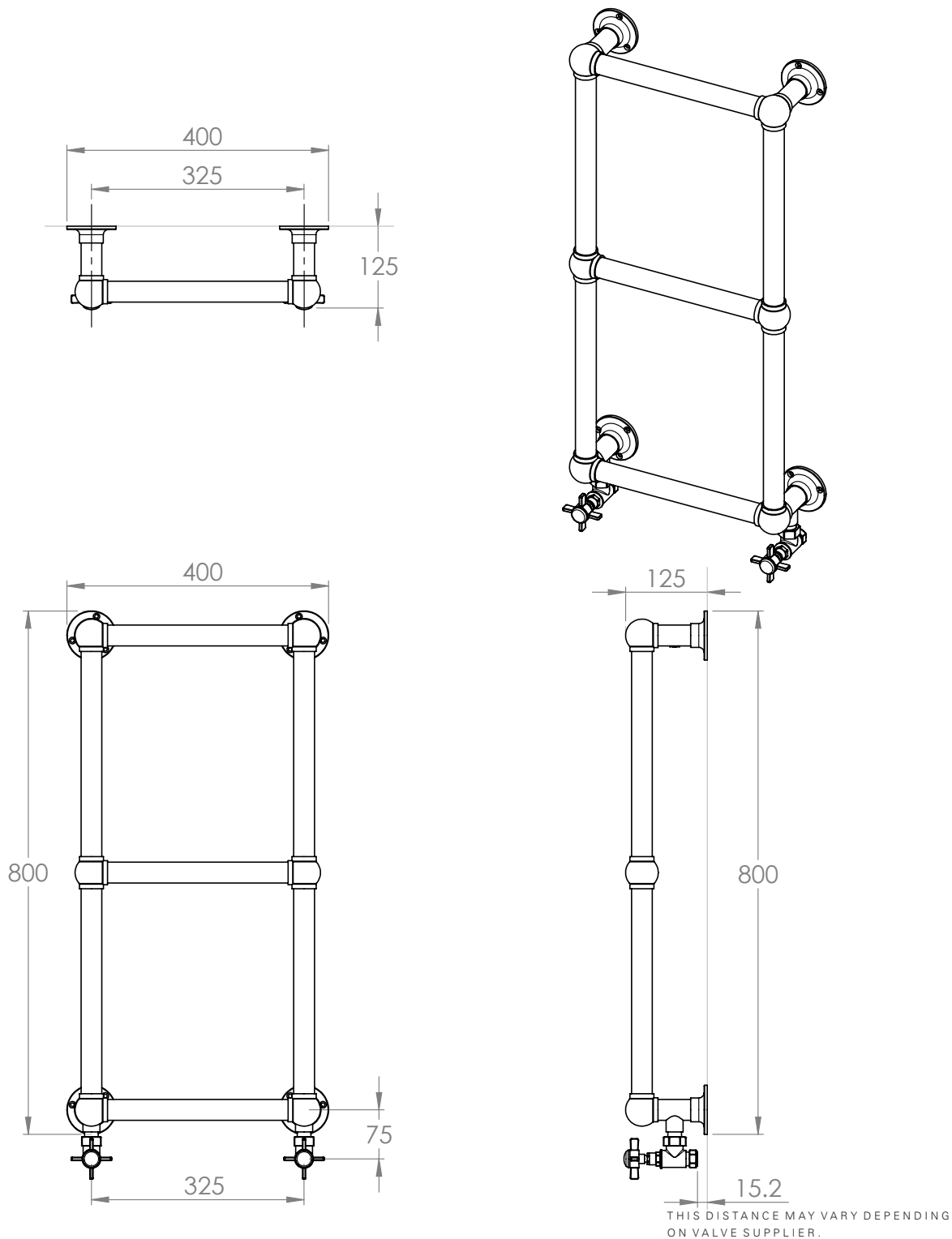

PORTER

"STANDARD" HEPWORTH TOWEL RAIL SMALL WALL

TR728

PACKAGE COMPONENTS

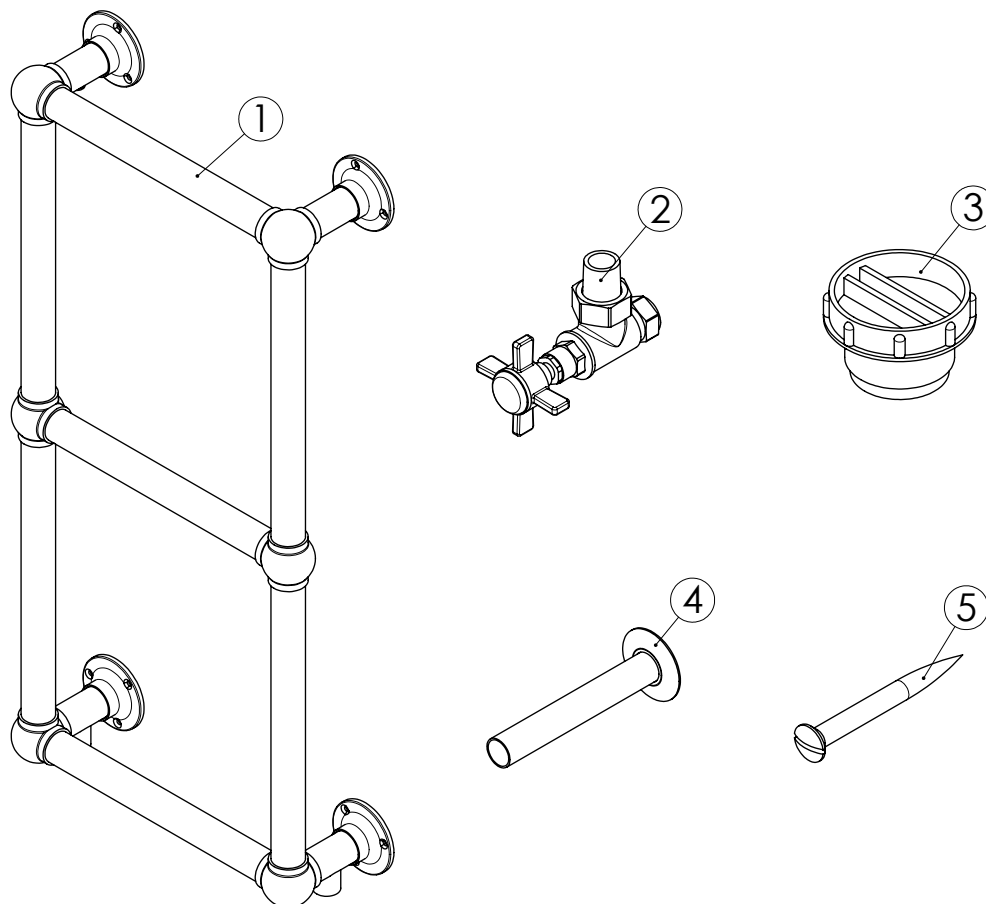

ITEM	PART	QNTY
1	TOWEL RAIL	1
2	VALVE	2
3	PLASTIC CAP (mounted on rail)	2
4	SLEEVING KIT	2
5	SCREW	12

TOOLS REQUIRED

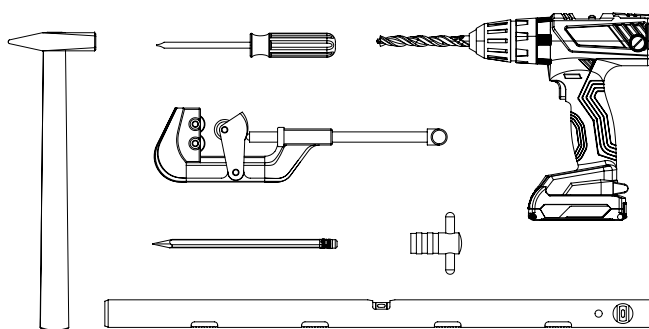

OTHER COMPONENTS REQUIRED

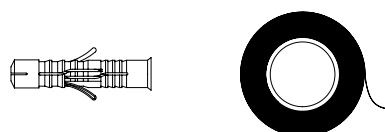

PORTER

"STANDARD" HEPWORTH TOWEL RAIL SMALL WALL

TR728

ASSEMBLY INSTRUCTIONS

1. PRE-INSTALLATION PLUMBING

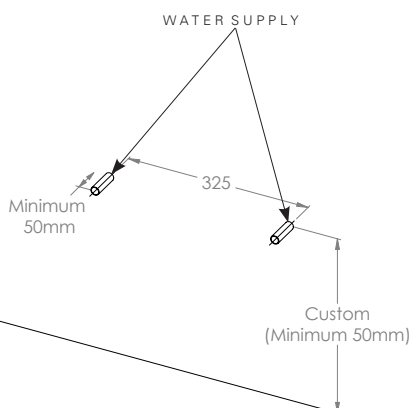

2. VALVES ASSEMBLING

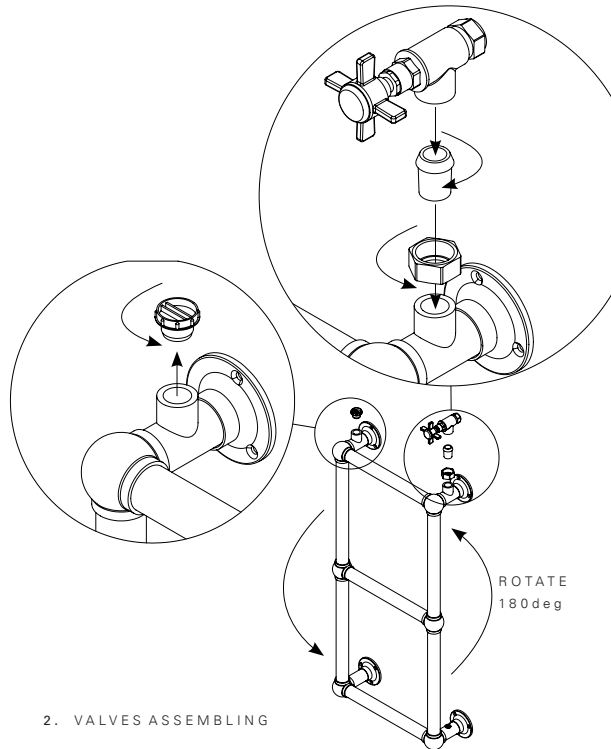

3. PIPES AND SLEEVING KIT CUTTING

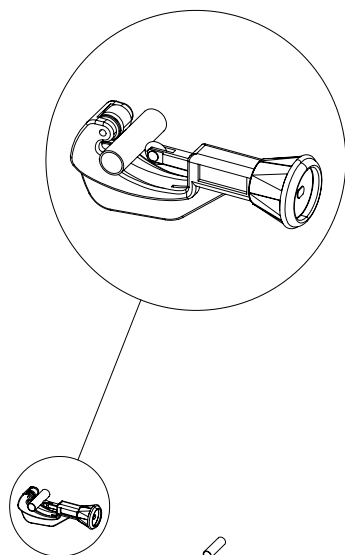

4. PLACEMENT SETTINGS AND ADJUSTMENT

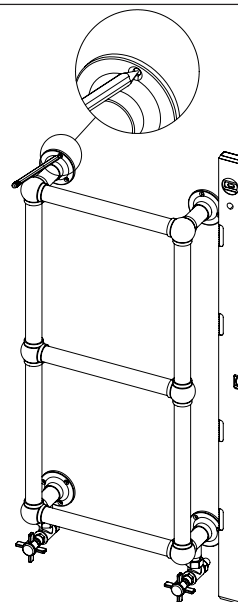

PORTER

"STANDARD" HEPWORTH TOWEL RAIL SMALL WALL

TR728

ASSEMBLY INSTRUCTIONS

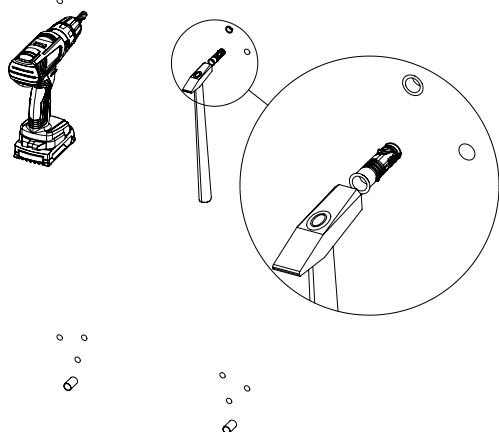

5. FITTING WALL PLUGS

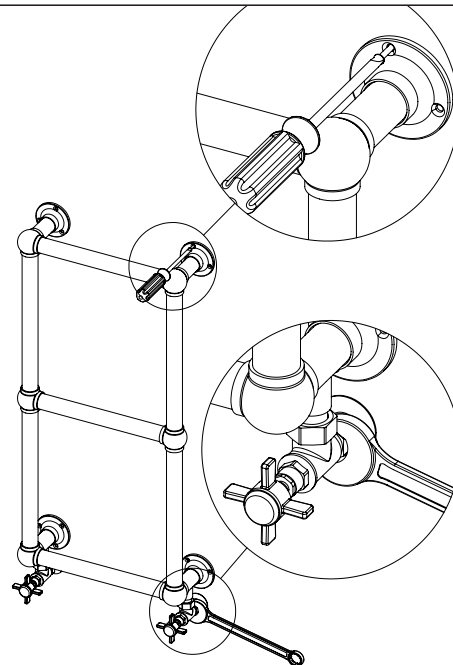

6. FIXING TOWEL RAIL

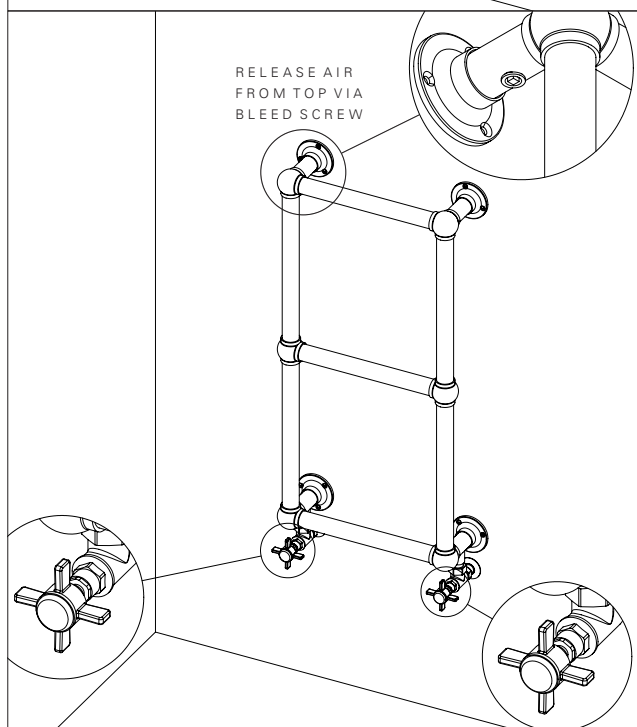

7. RELEASE AIR

PORTER

"STANDARD" HEPWORTH TOWEL RAIL SMALL WALL

TR728

DELIVERY

For delivery of your porter products, access for a small truck may be required. If this is not possible, please inform your porter representative prior to delivery. Once your product has been delivered to your door by our chosen transport partner, it must be carried into your home and fitted by your chosen builder, plumber, contractor etc. It is not the delivery driver's responsibility to carry the product inside the home, but at his/her discrepancy they may assist if the unit is being placed in a garage or similar for storage etc.

When your product is being delivered, please take the time to check over all items by removing the outer packaging or by opening the delivery box by lifting the lid off followed by the sides and finally the rest of the packaging. Any signs of damage during transport should be reported immediately.

HANDLING

For safe handling and manoeuvring of all large products, marble/stone tops, we recommend that 2 people are used to move and lift at all times. Carry and store the marble/stone top and backsplash on its edge at all times. Full pre-plumbing dimensions and instructions are available to download from our website for your chosen unit at:
www.porterbathroom.com

- i. When manoeuvring porter's vanities or baths, the marble/stone top will not be permanently fixed to the unit or bath at this point and should be lifted carefully off by 2 persons and placed carefully aside from the unit.
- ii. The main base can then be carried into the bathroom and fitted into position.
- iii. Before installing the marble onto the base, please ensure all pipework is in its correct position, drilling any necessary holes in the rear of the unit wall.
- iv. Fix the unit to the wall on both sides through the guide holes provided.
- v. When fitting the top, place it on its edge at the rear of the unit before lowering the front into position. If needed, to remove the top, lift the front of the marble/stone top up first until vertical and carry the top away, always keeping the top vertical.
- vi. When fitting the marble top on permanently, we recommend using a clear natural silicone to bond it to the base, using the same natural silicone to bond the backsplash to the wall.

P O R T E R

"STANDARD" HEPWORTH TOWEL RAIL SMALL WALL

TR728

PRODUCT CARE

Metal

For heated Bellmax and towel rail, ensure the heating is OFF before any maintenance.

Chrome and nickel finish, it is important that you clean the metal only with a solution of soapy water and a soft dry cloth, and it is advisable not to use any form of chemical abrasive that is likely to damage the surface.

Brass only is a raw finish and can be left to mature ageing gracefully or if you wish for it to remain to a bright lustre you will be able to use a relevant brass polish of your choice, please refer to the polish manufacturers recommendations.

PORTER

"DUAL FUEL" HEPWORTH TOWEL RAIL SMALL WALL

Porter heated towel rails are constructed from the highest grade corrosion resistant DZR brass. The quality of finish is reminiscent of yacht rail styling, durable and beautiful. The dual fuel floor mounted models can be configured with a hidden electrical heating element. Each unit is rigorously tested to ensure the correct heat output and further pressure tested to fourteen bar.

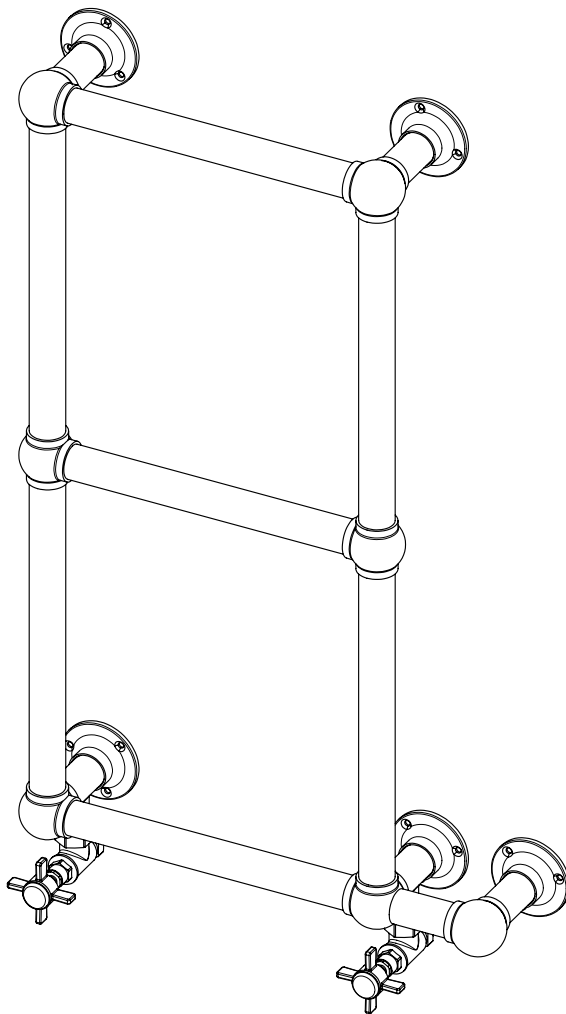





TR728

	MM	"
Width	500	19.7
Height	800	31.5
Depth	125	4.9

DETAILS

Made from high grade corrosion resistant DZR brass. 450 BTU

FINISHES

Polished chrome	
Silver nickel	
Polished brass	
Antique brass	

IMPORTANT

In order to properly use you "Dual Fuel" Porter towel rail outside of the winter season it is important to close both valves to isolate the towel rail of the rest of the central heating system when the latter has been turned off. This will ensure the best performance of the heating element.

PORTER

"DUAL FUEL" HEPWORTH TOWEL RAIL SMALL WALL

TR728

PLAN AND DIMENSIONS

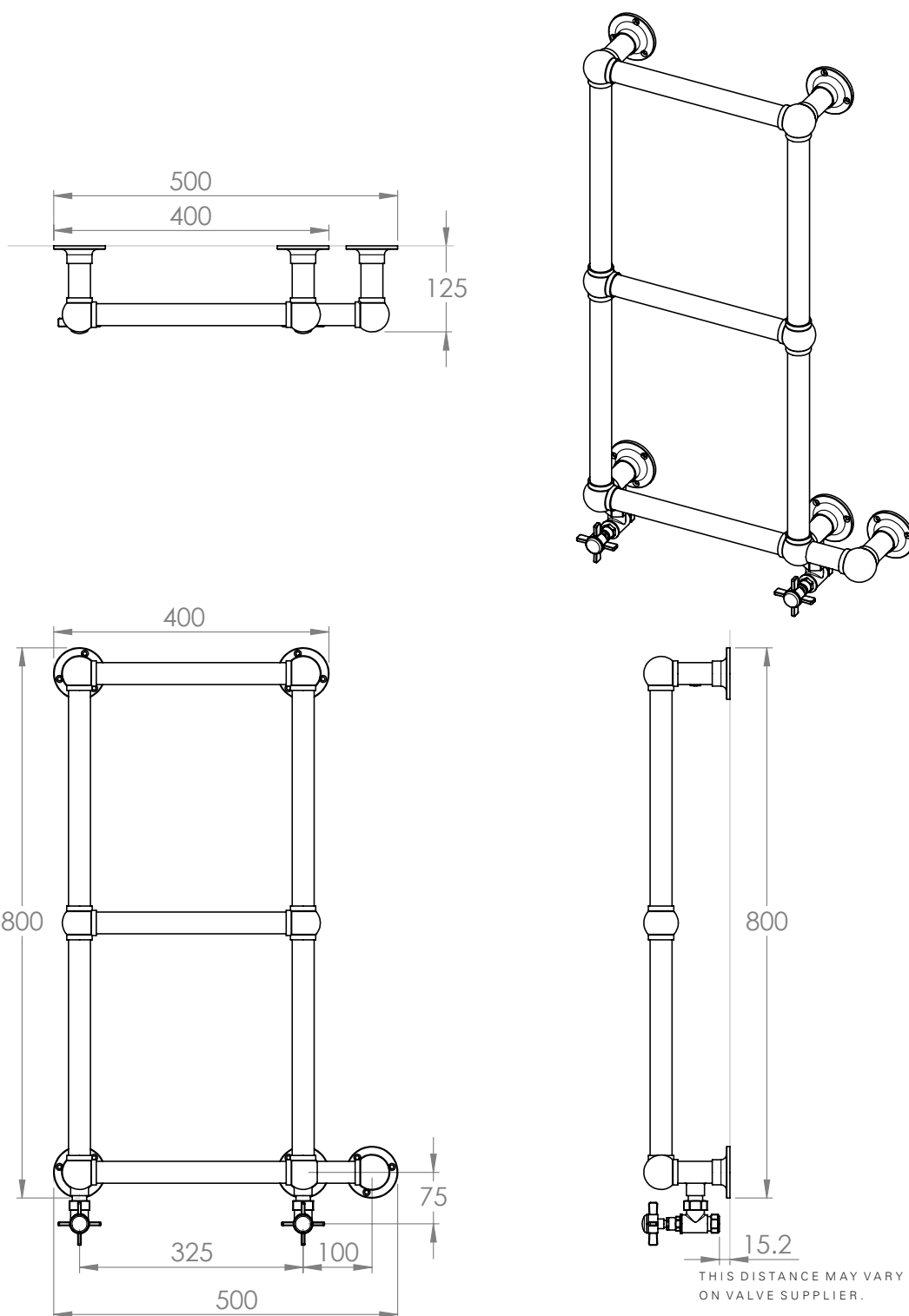

PORTER

"DUAL FUEL" HEPWORTH TOWEL RAIL SMALL WALL

TR728

PACKAGE COMPONENTS

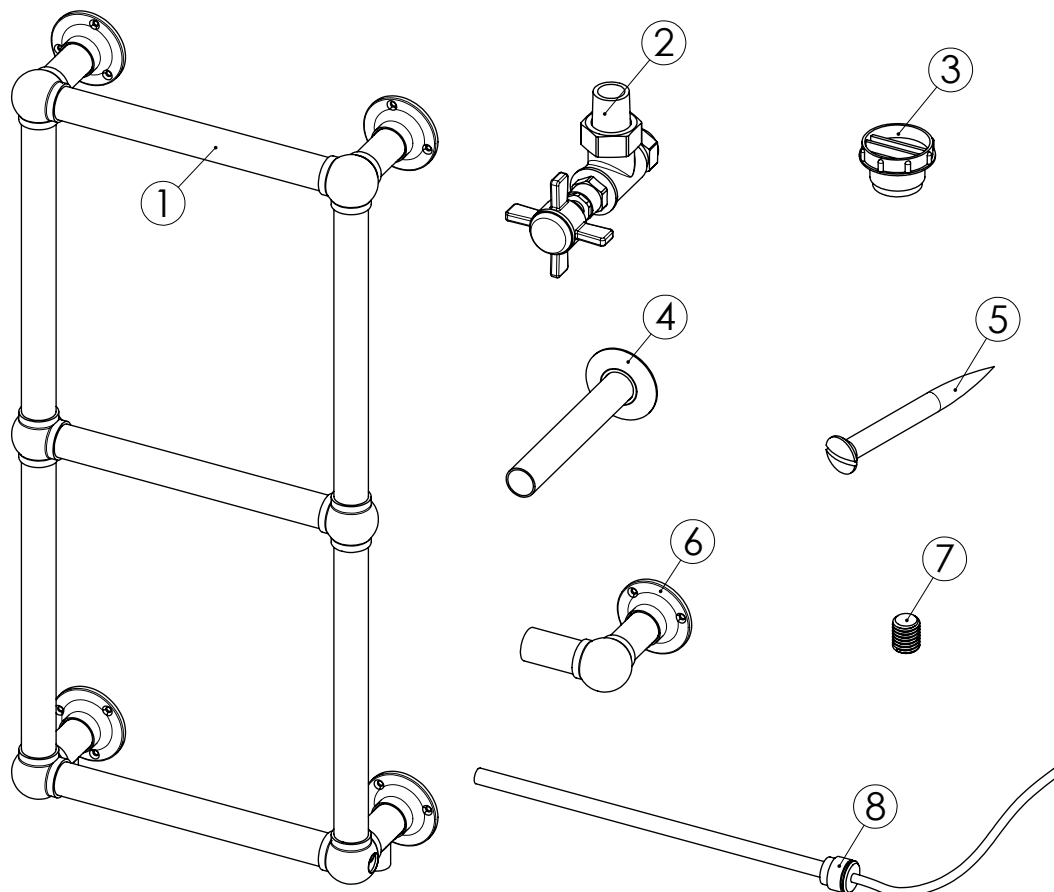

ITEM	PART	QNTY
1	TOWEL RAIL	1
2	VALVE	2
3	PLASTIC CAP (mounted on rail)	3
4	SLEEVING KIT	2
5	SCREW	15
6	HEATING ELEMENT COVER	1
7	GRUB SCREW	1
8	HEATING ELEMENT	1

TOOLS REQUIRED

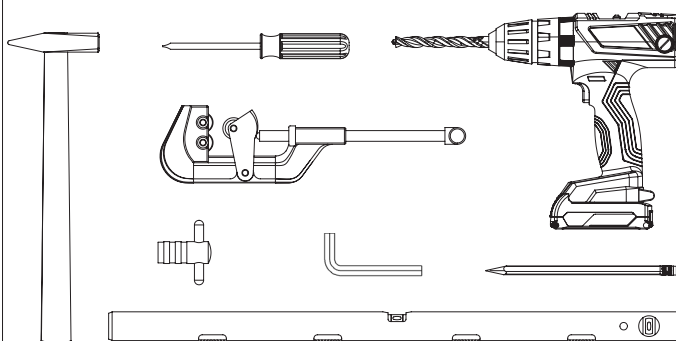

OTHER COMPONENTS REQUIRED



PORTER

"DUAL FUEL" HEPWORTH TOWEL RAIL SMALL WALL

TR728

ASSEMBLY INSTRUCTIONS

1. PRE-INSTALLATION PLUMBING

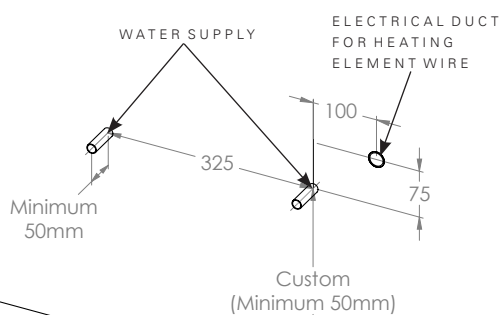

2. ELEMENT ASSEMBLING

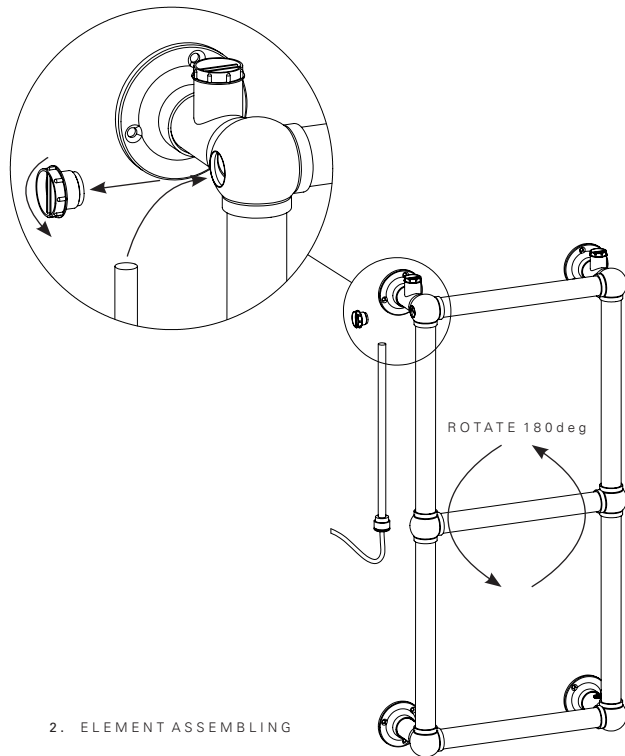

3. VALVES ASSEMBLING

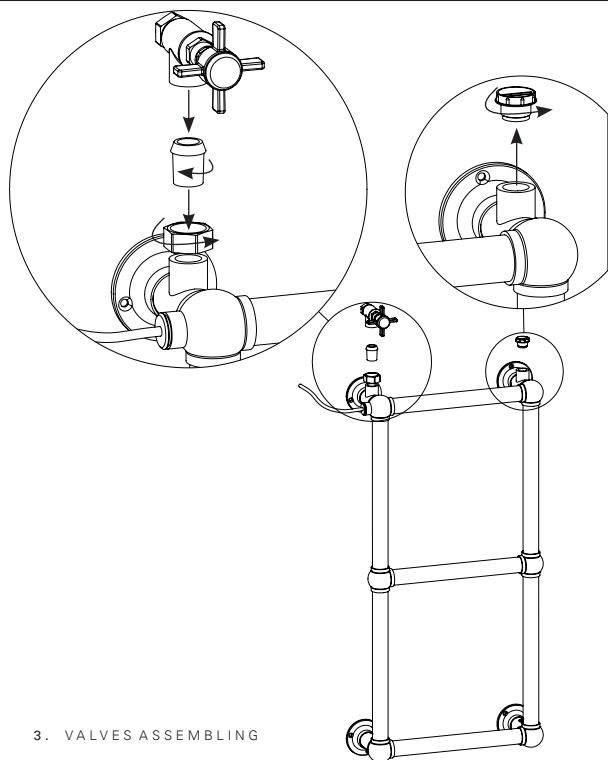

4. PIPES AND SLEEVING KIT CUTTING

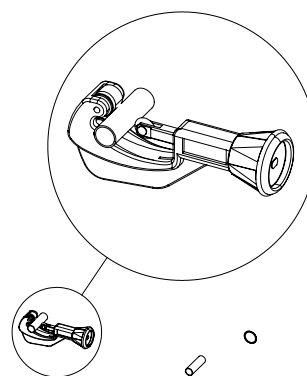

PORTER

"DUAL FUEL" HEPWORTH TOWEL RAIL SMALL WALL

TR728

ASSEMBLY INSTRUCTIONS

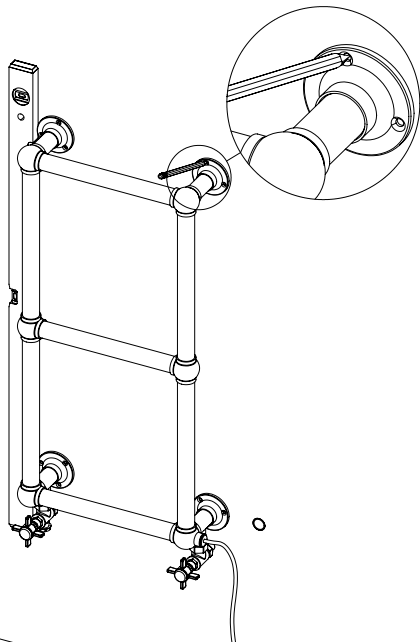

5. PLACEMENT SETTINGS AND ADJUSTMENT

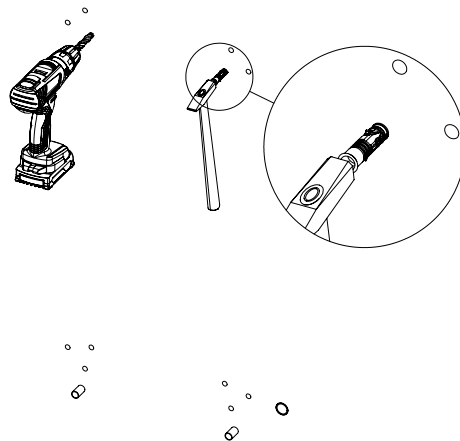

6. FITTING WALL PLUGS

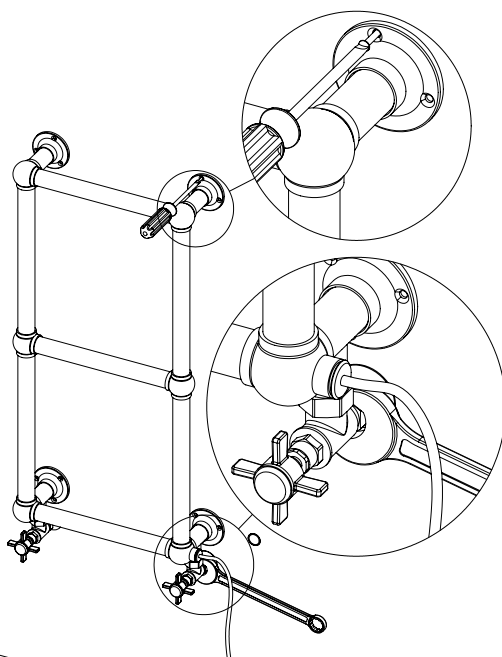

7. FIXING TOWEL RAIL

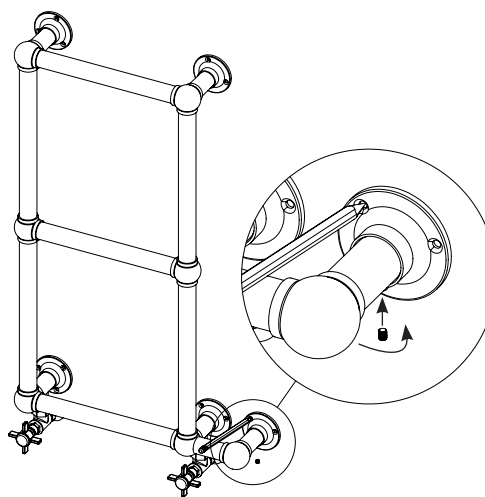

8. PLACEMENT OF ELEMENT COVER

PORTER

"DUAL FUEL" HEPWORTH TOWEL RAIL SMALL WALL

TR728

ASSEMBLY INSTRUCTIONS

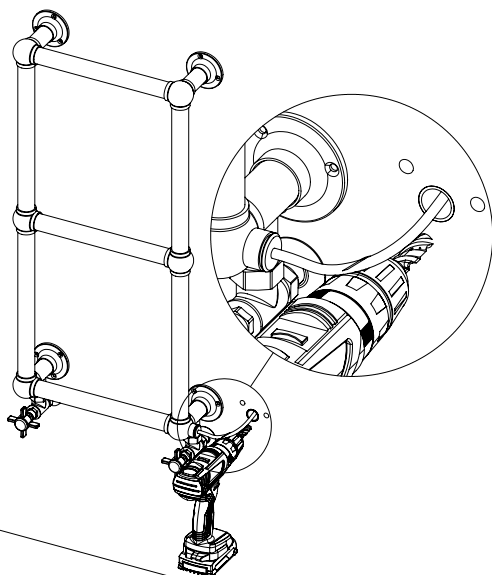

9. FITTING WALL PLUGS (ELEMENT COVER)

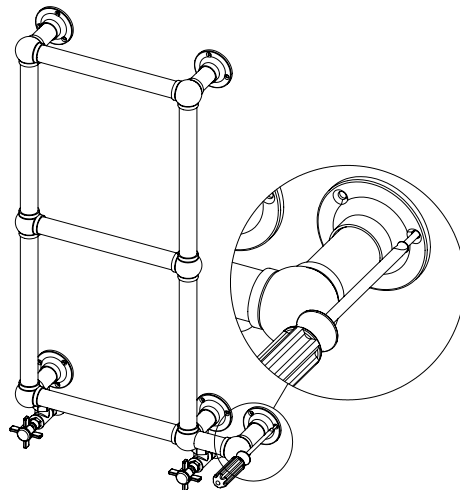

10. FIXING ELEMENT COVER

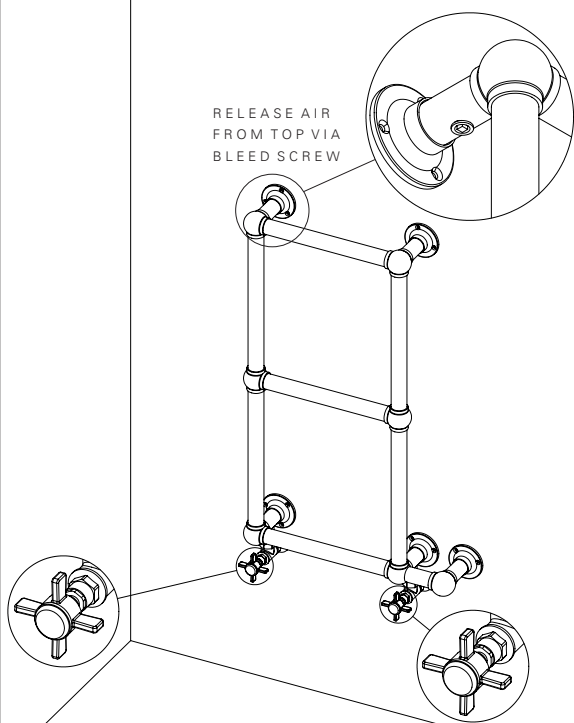

11. RELEASE AIR

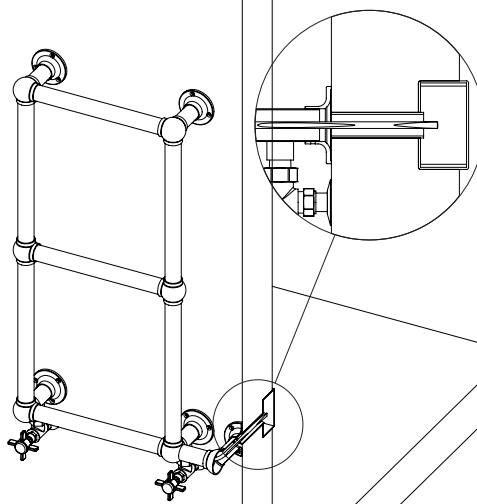

12. FUSE BOX POSITION

P O R T E R

"DUAL FUEL" HEPWORTH TOWEL RAIL SMALL WALL

TR728

DELIVERY

For delivery of your porter products, access for a small truck may be required. If this is not possible, please inform your porter representative prior to delivery. Once your product has been delivered to your door by our chosen transport partner, it must be carried into your home and fitted by your chosen builder, plumber, contractor etc. It is not the delivery driver's responsibility to carry the product inside the home, but at his/her discrepancy they may assist if the unit is being placed in a garage or similar for storage etc.

When your product is being delivered, please take the time to check over all items by removing the outer packaging or by opening the delivery box by lifting the lid off followed by the sides and finally the rest of the packaging. Any signs of damage during transport should be reported immediately.

HANDLING

For safe handling and manoeuvring of all large products, marble/stone tops, we recommend that 2 people are used to move and lift at all times. Carry and store the marble/stone top and backsplash on its edge at all times. Full pre-plumbing dimensions and instructions are available to download from our website for your chosen unit at:
www.porterbathroom.com

- i. When manoeuvring porter's vanities or baths, the marble/stone top will not be permanently fixed to the unit or bath at this point and should be lifted carefully off by 2 persons and placed carefully aside from the unit.
- ii. The main base can then be carried into the bathroom and fitted into position.
- iii. Before installing the marble onto the base, please ensure all pipework is in its correct position, drilling any necessary holes in the rear of the unit wall.
- iv. Fix the unit to the wall on both sides through the guide holes provided.
- v. When fitting the top, place it on its edge at the rear of the unit before lowering the front into position. If needed, to remove the top, lift the front of the marble/stone top up first until vertical and carry the top away, always keeping the top vertical.
- vi. When fitting the marble top on permanently, we recommend using a clear natural silicone to bond it to the base, using the same natural silicone to bond the backsplash to the wall.

PORTER

"DUAL FUEL" HEPWORTH TOWEL RAIL SMALL WALL

TR728

PRODUCT CARE

Metal

For heated Bellmax and towel rail, ensure the heating is OFF before any maintenance.

Chrome and nickel finish, it is important that you clean the metal only with a solution of soapy water and a soft dry cloth, and it is advisable not to use any form of chemical abrasive that is likely to damage the surface.

Brass only is a raw finish and can be left to mature ageing gracefully or if you wish for it to remain to a bright lustre you will be able to use a relevant brass polish of your choice, please refer to the polish manufacturers recommendations.

PORTER

"ELECTRIC" HEPWORTH TOWEL RAIL SMALL WALL

Porter heated towel rails are constructed from the highest grade corrosion resistant DZR brass. The quality of finish is reminiscent of yacht rail styling, durable and beautiful. The dual fuel floor mounted models can be configured with a hidden electrical heating element. Each unit is rigorously tested to ensure the correct heat output and further pressure tested to fourteen bar.

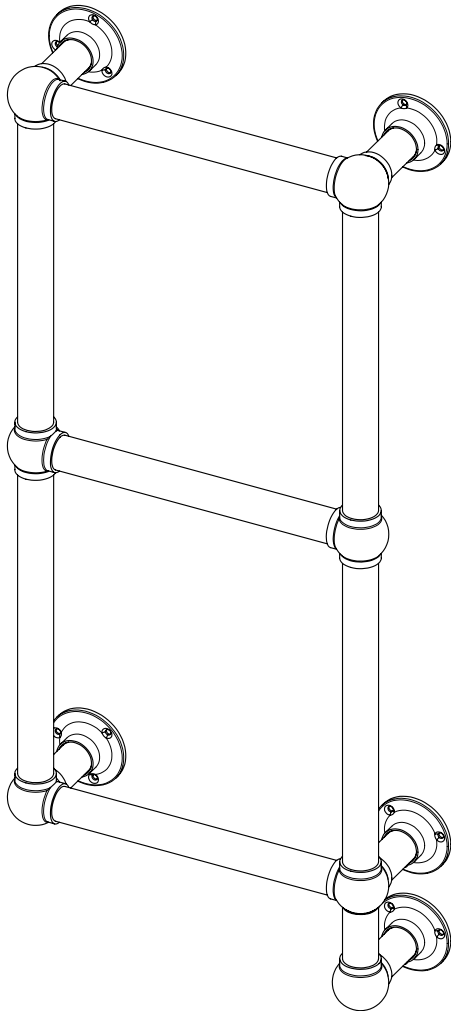

TR728

	MM	"
Width	400	15.7
Height	900	35.4
Depth	125	4.9

DETAILS

Made from high grade corrosion resistant DZR brass. 450 BTU

FINISHES

Polished chrome



Silver nickel



Polished brass



Antique brass



PORTER

"ELECTRIC" HEPWORTH TOWEL RAIL SMALL WALL

TR728

Porter bathroom would like to thank you for purchasing one of our handcrafted electric heated towel warmers made in our own workshops in the United Kingdom using only the finest of materials and a skill that has been handed down for decades. We manufacture every item individually in limited numbers using raw materials so a truly traditional product.

IN THE BOX

An accompanying kit including brass screws, a fluid bottle, a bleed valve key, and an electric element.

This fluid needs to be poured into your electric towel warmer before you install it, this fluid is a vital part of the installation and when mixed with water acts as an inhibitor.

We recommend that you allow a qualified professional to deal with this task, if you are planning to add the solution yourself, this guide will take you through how to do it correctly and safely.

Preparation to install

Your Porter towel warmer is made from DZR Brass and is finished to your own specifications, so it is important to handle it with care.

- The Towel warmer also comes with everything you need to hang them. Please check these items are all with your order.
- Also make sure the area you are working in is completely free from obstructions.
- Additionally, you will need approximately 3 litres of water and a small funnel.

Installation on to the wall

The electric pencil element is provided with all of our electric towel rails, and this must be fitted to the bottom of the towel warmer before it is mounted on the wall.

- Please turn the towel warmer upside down and you will see a red blanking plug, please remove.
- Pour the fluid bottle into the now top of the rail using the funnel. Once all the fluid has been poured in, pour in the water until about one inch from the top of the towel rail.
- Insert the element into the hole and tighten with an appropriate tool and clean away any excess fluids.
- Position and install the towel warmer.
- Connecting the electric as required by the relevant laws governed by your particular country.
- Power up and when the heated towel rail reaches its operating temperature you will be able to bleed the towel warmer, this takes approximately 1 hour initially.
- It is important to bleed any excess air using the air vent key, it would be advisable to have a dry cloth under the vent so that it may protect the environment around the towel warmer.

Important

- Please tighten the air vent when the towel warmer is hot, this will then be sealed and ready for use.
- More installation information can be found in the following pages.
- In the unlikely event that you have any problems with installation please contact us.

PORTER

"ELECTRIC" HEPWORTH TOWEL RAIL SMALL WALL

TR728

PLAN AND DIMENSIONS

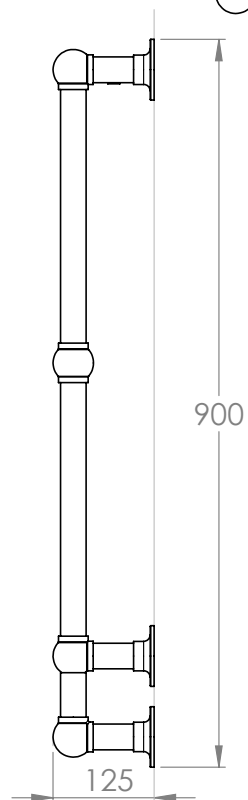
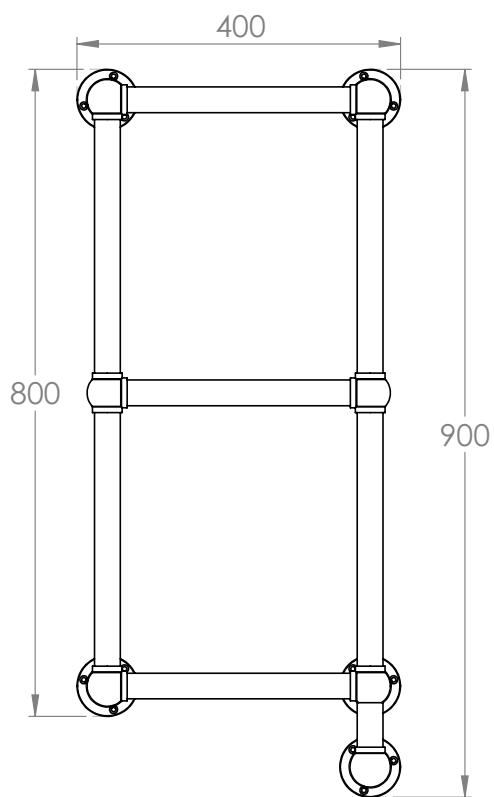
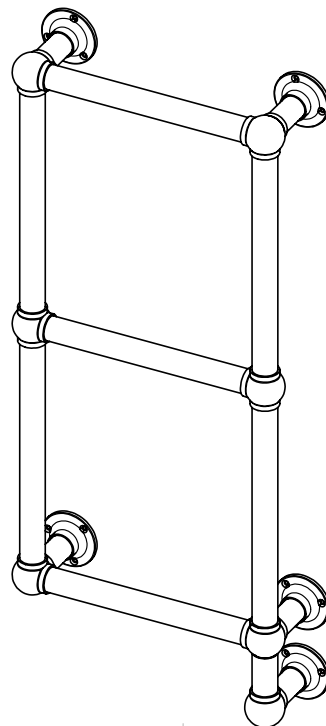
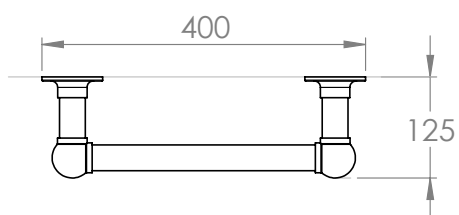

PORTER

"ELECTRIC" HEPWORTH TOWEL RAIL SMALL WALL

TR728

PACKAGE COMPONENTS

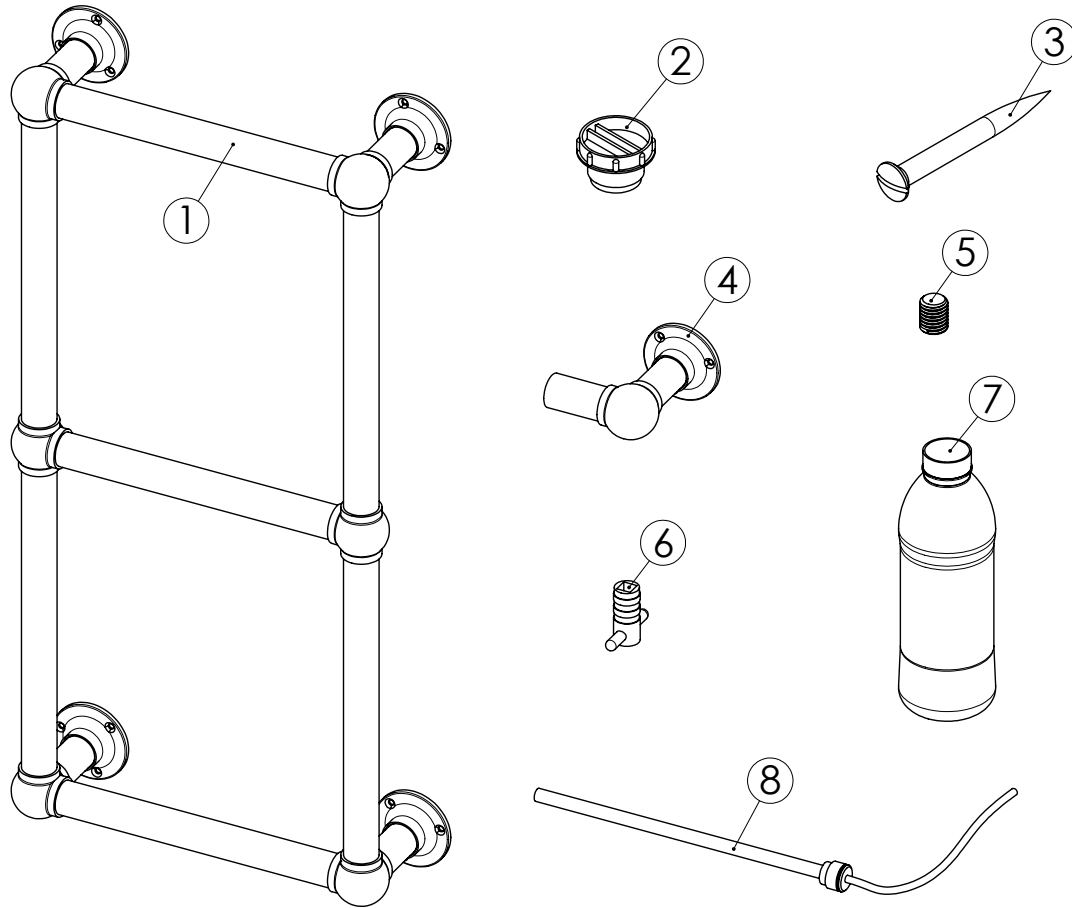

ITEM	PART	QNTY
1	TOWEL RAIL	1
2	PLASTIC CAP (mounted on rail)	1
3	SCREW	15
4	HEATING ELEMENT COVER	1
5	GRUB SCREW	1
6	BLEED KEY	1
7	BOTTLE OF FLUID	1
8	HEATING ELEMENT	1

TOOLS REQUIRED

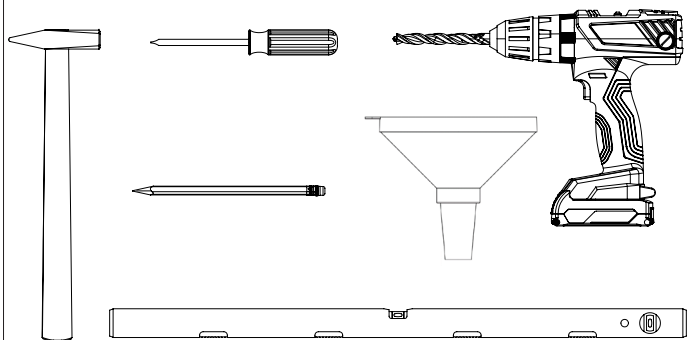

OTHER COMPONENTS REQUIRED

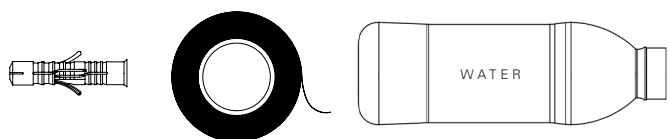

PORTER

"ELECTRIC" HEPWORTH TOWEL RAIL SMALL WALL

TR728

ASSEMBLY INSTRUCTIONS

1. ELECTRIC LAYOUT

ELECTRICAL DUCT FOR HEATING ELEMENT WIRE

Custom (Minimum 50mm)

2. FUNNEL PLACEMENT

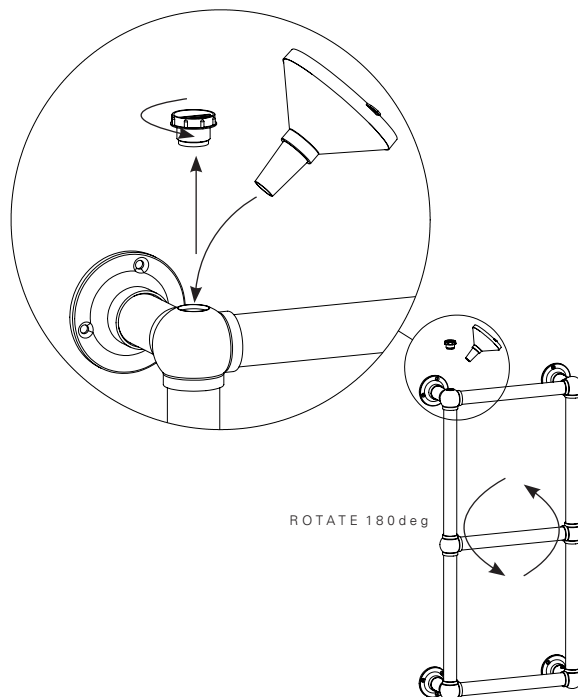

3. TOWEL RAIL FILLING

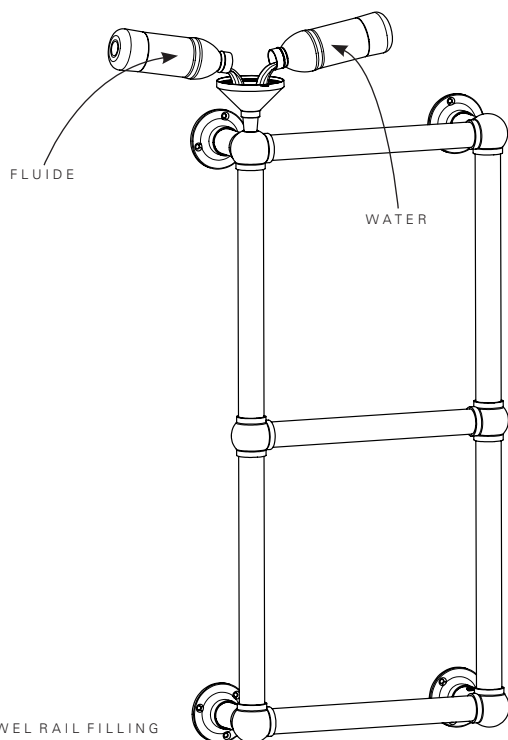

4. ELEMENT ASSEMBLING

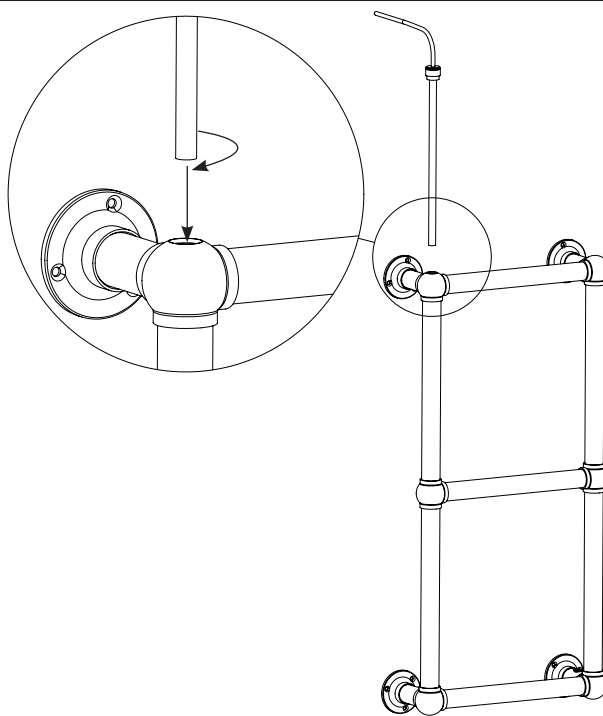

PORTER

"ELECTRIC" HEPWORTH TOWEL RAIL SMALL WALL

TR728

ASSEMBLY INSTRUCTIONS

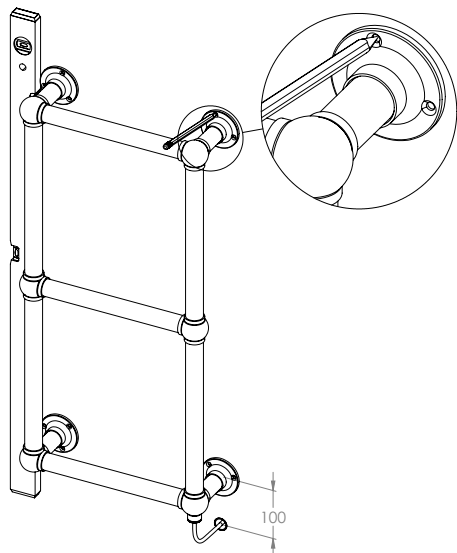

5. PLACEMENT SETTINGS AND ADJUSTMENT

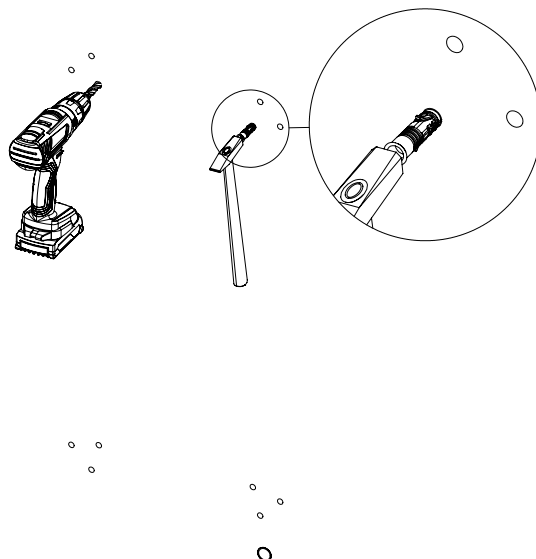

6. FITTING WALL PLUGS

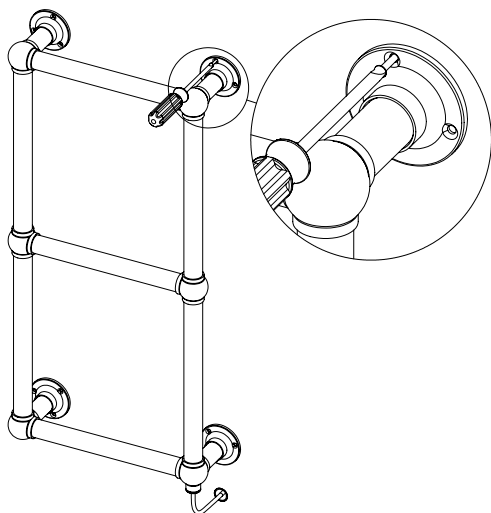

7. FIXING TOWEL RAIL

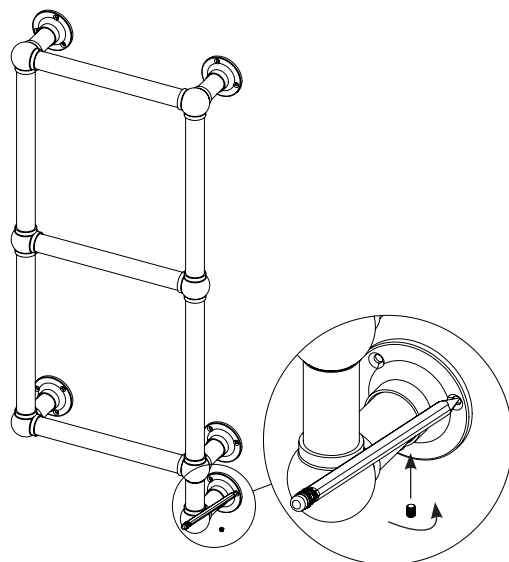

8. PLACEMENT OF ELEMENT COVER

PORTER

"ELECTRIC" HEPWORTH TOWEL RAIL SMALL WALL

TR728

ASSEMBLY INSTRUCTIONS

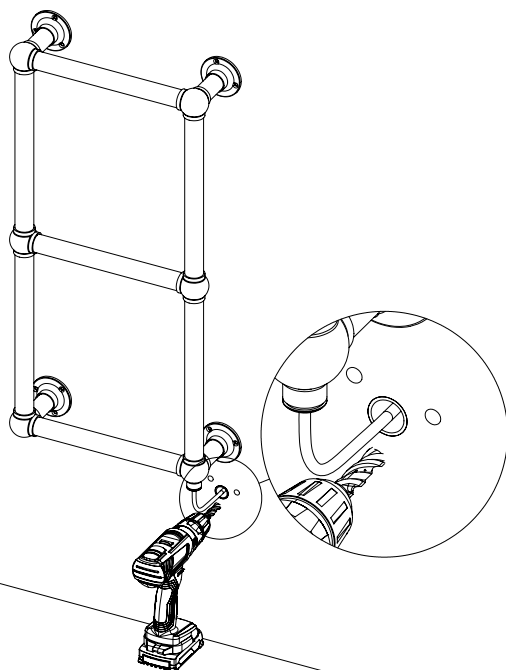

9. FITTING WALL PLUGS (ELEMENT COVER)

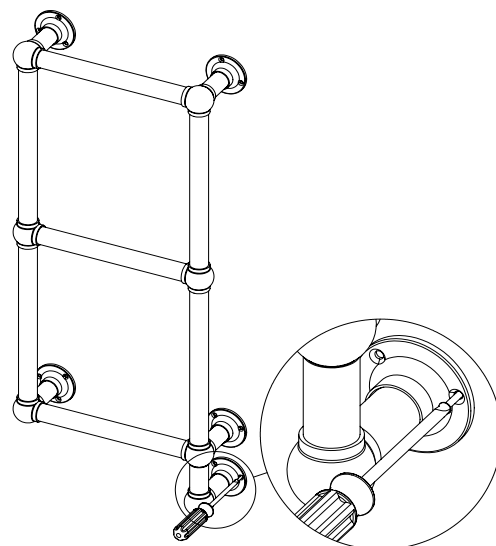

10. FIXING ELEMENT COVER

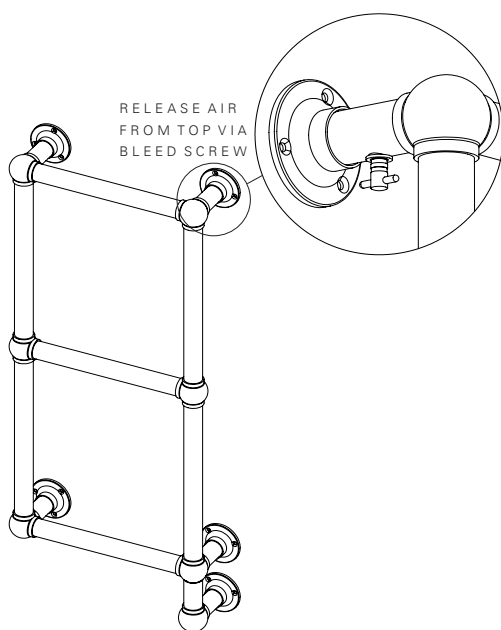

11. RELEASE AIR

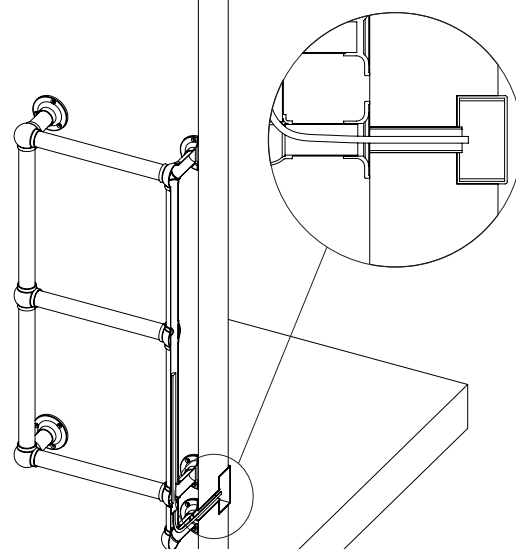

12. FUSE BOX POSITION

PORTER

"ELECTRIC" HEPWORTH TOWEL RAIL SMALL WALL

TR728

DELIVERY

For delivery of your porter products, access for a small truck may be required. If this is not possible, please inform your porter representative prior to delivery. Once your product has been delivered to your door by our chosen transport partner, it must be carried into your home and fitted by your chosen builder, plumber, contractor etc. It is not the delivery driver's responsibility to carry the product inside the home, but at his/her discrepancy they may assist if the unit is being placed in a garage or similar for storage etc.

When your product is being delivered, please take the time to check over all items by removing the outer packaging or by opening the delivery box by lifting the lid off followed by the sides and finally the rest of the packaging. Any signs of damage during transport should be reported immediately.

HANDLING

For safe handling and manoeuvring of all large products, marble/stone tops, we recommend that 2 people are used to move and lift at all times. Carry and store the marble/stone top and backsplash on its edge at all times. Full pre-plumbing dimensions and instructions are available to download from our website for your chosen unit at:
www.porterbathroom.com

- i. When manoeuvring porter's vanities or baths, the marble/stone top will not be permanently fixed to the unit or bath at this point and should be lifted carefully off by 2 persons and placed carefully aside from the unit.
- ii. The main base can then be carried into the bathroom and fitted into position.
- iii. Before installing the marble onto the base, please ensure all pipework is in its correct position, drilling any necessary holes in the rear of the unit wall.
- iv. Fix the unit to the wall on both sides through the guide holes provided.
- v. When fitting the top, place it on its edge at the rear of the unit before lowering the front into position. If needed, to remove the top, lift the front of the marble/stone top up first until vertical and carry the top away, always keeping the top vertical.
- vi. When fitting the marble top on permanently, we recommend using a clear natural silicone to bond it to the base, using the same natural silicone to bond the backsplash to the wall.

PORTER

"ELECTRIC" HEPWORTH TOWEL RAIL SMALL WALL

TR728

PRODUCT CARE

Metal

For heated Bellmax and towel rail, ensure the heating is OFF before any maintenance.

Chrome and nickel finish, it is important that you clean the metal only with a solution of soapy water and a soft dry cloth, and it is advisable not to use any form of chemical abrasive that is likely to damage the surface.

Brass only is a raw finish and can be left to mature ageing gracefully or if you wish for it to remain to a bright lustre you will be able to use a relevant brass polish of your choice, please refer to the polish manufacturers recommendations.